

Key Features

- Rotary absolute position measurement with 6-bit resolution
- 64 positions within full 360° degree rotation range
- Rotation speed of magnetic source up to 30,000 rpm
- Digital output signal with Synchronous Serial Interface (SSI)
- Wide temperature range: - 40°C to +125°C (-40°F to +257°F)
- Low power dissipation: less than 5μW per sample
- System on Chip: Hall effect sensors and signal processing combined on a single chip
- Simple permanent magnetic source required

Benefits

- Non-contact switching providing high reliability and long mechanical life time. Ideal for electrically isolated applications.
- Extremely compact SOIC-8 package
- Ease of implementation with reduced number of external components
- User specific zero position programmable into internal OTP
- Multiple sensors connected in daisy chain mode through simple 3 wire connection
- Flexibility for different operation modes
- No calibration needed
- Extremely tolerant to magnetic and harsh environment
- Tolerant to magnetic source misalignment

Applications

- Motion control
- Precision linear- or angular position sensing
- Precision angular encoding
- Software re-configurable rotary switch
- Isolated rotary switch for safety critical applications
- Alternative to potentiometers

General Description

The AS5020 device provides the absolute angular position encoding of a simple magnet source that is placed at the device's surface. A total of 64 absolute angular positions are available within the full range of 360° (typical sector size: 5.625°).



Figure 1 Placement of AS5020 device and magnet source

The device includes a Hall sensor array, the signal conditioning and the post processing needed to generate a 6-bit binary code. The binary code may be accessed via the Synchronous Serial Interface (SSI). Zero-position programming allows one time programming of a user specific zero position between the device and the magnet source.

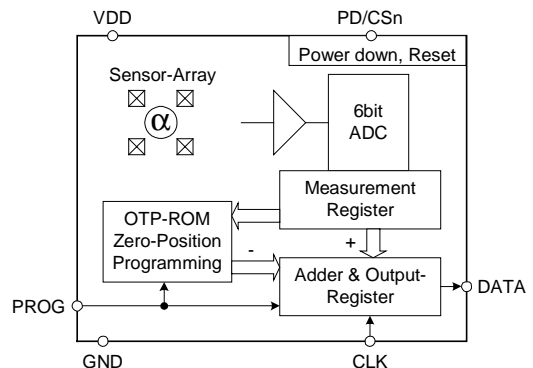
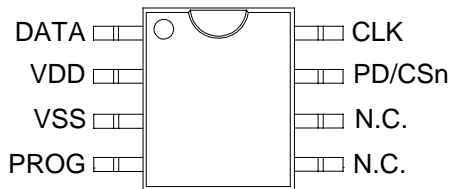

Figure 2 Block diagram

Pin Configuration



Pin Description

Pin #	Symbol	Type	Description
1	DATA	DO	DATA Output of the SSI. If PD/CSn=0, the measured angle data (6-bit value) is serially shifted out over this pin by the CLK, starting with the MSB. A NVR bit and a PARITY bit are added. Even Parity is given. (NVR=1 indicates a Non Valid Range of the magnetic field)
2	V _{DD}	AI	Positive Supply Voltage.
3	V _{SS}	AI	Negative Supply Voltage (GND).
4	PROG	DI	PROG ramming Input This pin is used to program the zero position into a non-volatile memory (One Time Programmable). The programmed value is subtracted from the actual measured angle. (This pin is also used for Data In during Daisy-Chain function)
5	N.C.	AI	Not Connected during operation. This pin is for manufacturers use only
6	N.C.	AI	Not Connected during operation. This pin is for manufacturers use only.
7	PD/CSn	DI	Power Down Input, Disable or Chip Select (active low). PD/CSn=0 activates the device and enables the measurement. PD/CSn=1 sets the device in power save mode and puts the DATA pin in high impedance (high Z) state.
8	CLK	DI	CLOCK Input of the SSI. Pin 8 serially clocks out the measured angle data at Pin 1 (DATA).

DI: Digital Input

AI: Analogue Input

DO: Digital Output

MSB: Most Significant Bit

Note: Pins 5 and 6 may be either left open or connected together

Functional Description

A Hall sensor array is used to convert the magnetic field distributed above the chip surface into a binary code. That represents the absolute angular position of the magnetic field with respect to the device.

The measured data is accessible via a Synchronous Serial Interface (SSI) by means of any micro-controller system.

The AS5020 is extremely tolerant of magnetic misalignment and of environmental influences due to the design adopted for the ratiometric measurement and Hall sensor conditioning circuitry.

Due to the very high level of system integration the AS5020 allows easy implementation of an angular measuring system. The AS5020 requires only two external components, a magnetic field source and a de-coupling capacitor.

As illustrated in figure 3, a simple two-pole permanent magnet may be used as the magnetic field source.

The magnet may be a diametrically magnetized, cylindrical standard magnet. Magnetic materials such as rare earth AlNiCo / SmCo5 or NdFeB are recommended. Typically the magnet size should be 3 to 6mm in diameter and 2 to 3mm in height. The typical distance between the magnet and the device is 0.5 to 1.5mm.

A magnetic field strength of typically $\pm 40\text{mT}$ is required at the package surface and a diameter of 1.6mm.

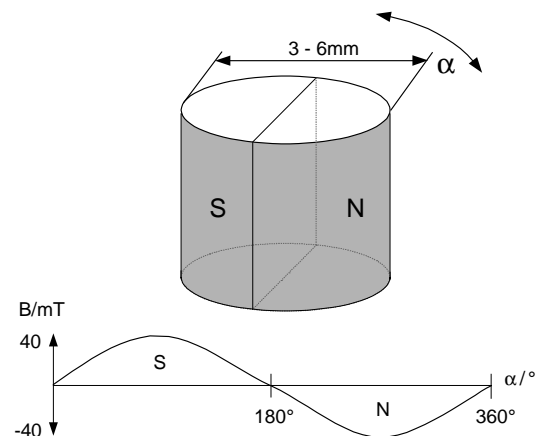

Figure 3 Typical magnet and magnetic field at the radius of 3mm

Functional Description of the Measurement Cycle and Data Output

See figure 4

Chip Select must be active low (PD/CSn=0) to enable measurement and to bring the output DATA from high impedance to logic low.

After a minimum measurement period, the first falling edge of CLK latches the current measured angular information of the applied magnetic field. The following rising edges of CLK shift the data out at DATA as the following 8-bit serial word:

Bits D<5:0> represent the measured angular data. The most significant bit is clocked out first.

NVR = 1 indicates a **Non Valid Range** of the magnetic field.

The PARITY bit provides integrity information about the serial word.

With Chip Select at logic high, the device returns to the power down state.

Programming of Continuous Read Out Mode and user specific zero position are described in more detail below.

Device Operating Modes

Single Measurement Mode is the default mode.

Continuous Read Out Mode and the user specific Zero Position may be programmed with a single pin programming at the DATA pin. This programming is permanently stored into the internal OTP ROM (One Time Programmable).

1. Single Measurement Mode and Daisy Chain Mode

This is the default mode and allows read out for the angular position of the magnetic source as shown in figure 4.

- 1.1 PD/CSn must be taken logic low. DATA will then switch from high impedance to logic low and the measurement will be initiated.
- 1.2 After the minimum measurement time, data will be internally latched at the falling edge of CLK.

- 1.3 After the rising edge of CLK the DATA is valid
- 1.4 The serial word readout sequence is D<5:0>, NVR and PARITY.
- 1.5 The next measurement is initiated with an active high pulse at PD/CSn with duration t_{reset}
- 1.6 During steps 1.4 and 1.5, while data is clocked out at DATA, the data at PROG is clocked into the device. Further clock pulses applied to CLK will serially clock this data out at DATA. This function allows implementation of the daisy chain function.

2. Continuous Read Out Mode

Continuous Read Out Mode needs to be programmed via PROG pin and allows continuous high speed measurement as shown in figure 5. The measured data will be internally latched and may be read if requested.

- 2.1 The falling edge of CLK synchronizes the DATA. Due to internal anti-collision of the value update the last completely measured value will be taken.
- 2.2 An external clock applied to CLK will shift the data from the output register of the device. The rising edge of the clock will latch the data to the output register. The 8 data bits may then be latched into an external micro-controller with the falling edges of the clock.
- 2.3 The serial word readout sequence is D<5:0>, NVR and PARITY.
- 2.4 After each readout sequence the output shift register is automatically refreshed at the falling edge of the ninth clock cycle

Note: Daisy Chain Configuration is not possible in this mode.

3. Programming of Zero Position and Continuous Read Out Mode

The possibility to program the user specific zero position gives many advantages (e.g. it simplifies the assembly at the production line, as the orientation of the magnet does not need to be considered. It also allows the design of software programmable rotary switches).

The initial zero position is shown in figure 7.

Timing Diagrams

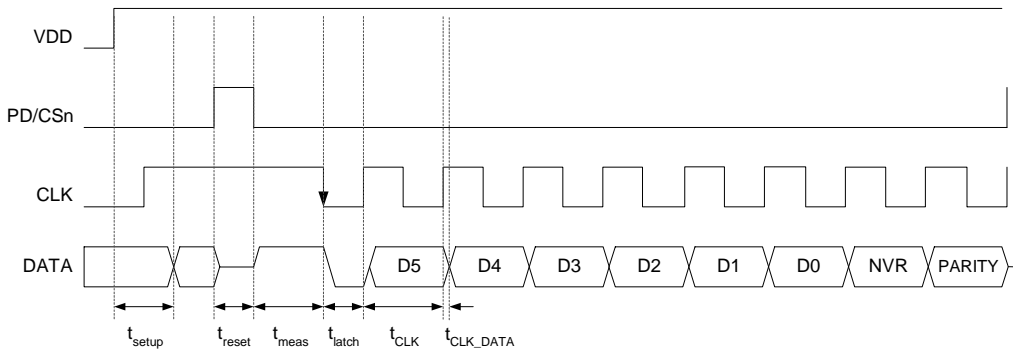

Figure 4 Timing diagram in Single Read Out mode

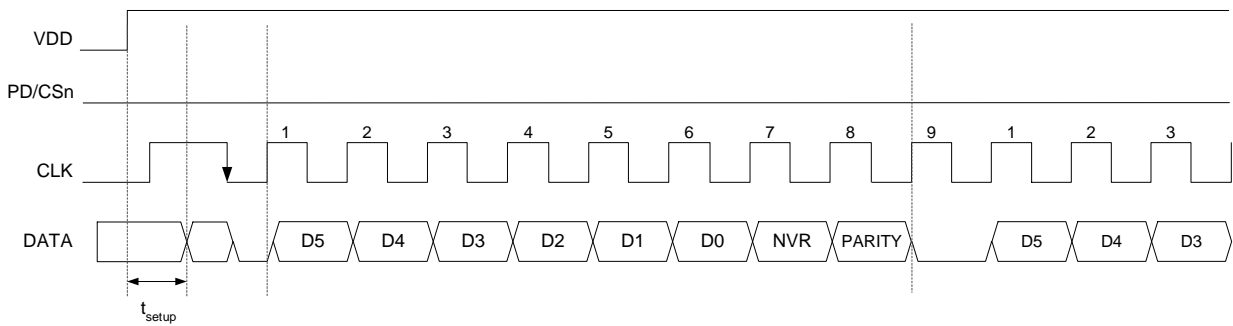

Figure 5 Timing diagram in Continuous Read Out mode

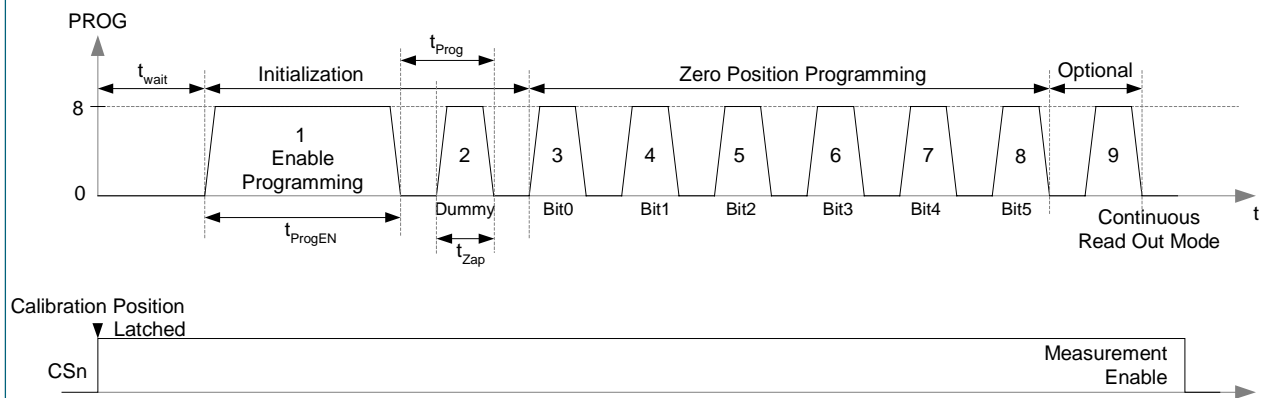

Figure 6 Programming sequence

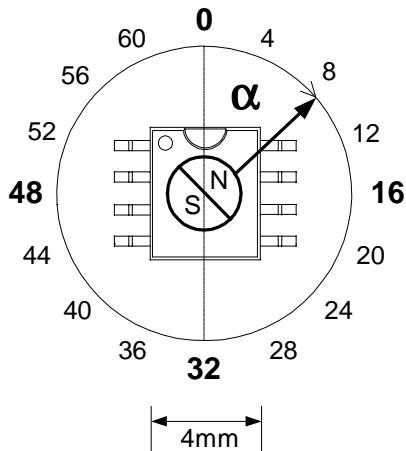

Figure 7 Initial angular orientation

Before programming the user specific zero position and Continuous Read Out Mode, the magnet must be adjusted in measurement mode (PD/CSn=0).

As shown in figure 6, the rising edge of PD/CSn measures the actual position and stores it internally for the permanent programming. PD/CS must be high during the whole programming sequence.

The first 8V pulse after the minimum waiting time t_{wait} sets the device into programming mode. It is important that this first pulse has a minimum duration of $t_{progEN} = 200 \mu s$. A chip response pulse at pin DATA confirms that the chip is in programming mode.

The following 7 pulses with 8V/5μs select the latched position information and permanently write the reference value into the OTP ROM.

An optional 9th pulse can be used to program the device to Continuous Read Out Mode.

4. Low Power Application

In low power applications the power down current of 500μA may be too high, in such a case the AS5020 needs to be completely switched off.

Due to the AS5020's capability of high speed measurement, a storage capacitor may be used to store the energy for the fast measurement and read out cycle of a minimum of 33μs. The sensor may then be completely switched off (S1 FET) if no position information is required. During this time the storage capacitor is recharged.

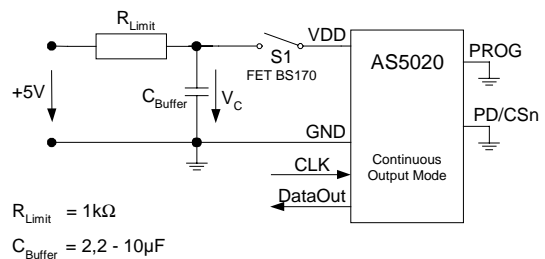

Figure 8 Schematics for basic low power application

At power on, after a minimum setup time of 20μs and a minimum latch time of 5μs the data may be clocked out with the maximum frequency within the supply voltage range of 4.5 to 5.5V. A supply voltage drop is allowed (see figure 9) In one measurement cycle, multiple readings in Continuous Output Mode may be performed to improve the safety.

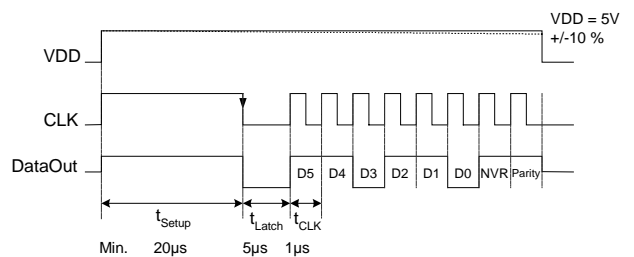

Figure 9 Timing diagram for low power application

Physical Placement of the Magnet

The magnet may be placed above or below the device. The distance must be within the specified range and the rotation axis should be aligned to the device center.

The recommended point for the axis is given by the crossing of the diagonals with respect to the leadframe.

Accurate placement is important to achieve the specified performance with respect to the temperature and the voltage ranges. Figure 10 shows the maximum allowed misalignment of the magnet with respect to the device, the typical values are shown in the table on page 10.

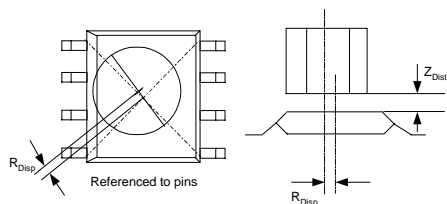

Figure 10 Maximum allowed misalignment of magnet with respect to the device

If misalignment is larger than specified, the device may continue to operate at reduced performance.

Serial Daisy Chain Configuration

Daisy Chain cascading of AS5020 devices allows serial read out of multiple sensors over a three-wire bus.

By interconnecting DATA and PROG pins and the control pins as shown in figure 11, the devices internal registers are reconfigured as a serial shift register.

Daisy Chain cascading allows minimization of interconnection lines.

After $n \times 9$ clock cycles each value of n sensors is available at the DATA pin of the first AS5020 device. A new measurement cycle may be initiated with the falling edge of CLK after a power down pulse at PD/CS $_n$.

Continuous Read Out Mode is not possible when using Daisy Chain configuration.

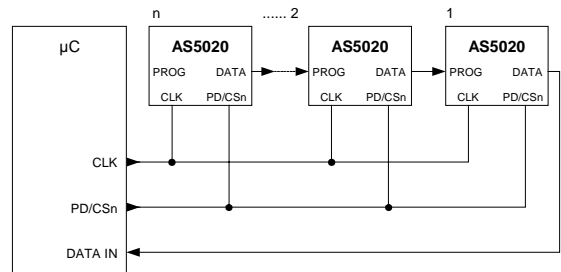

Figure 11 Typical Daisy Chain configuration

Parallel Configuration

Parallel configuration allows reading out a number of n sensors triggered by an external address decoder. Minimum access time results from this random access method. Continuous Read Out Mode is possible when using parallel configuration.

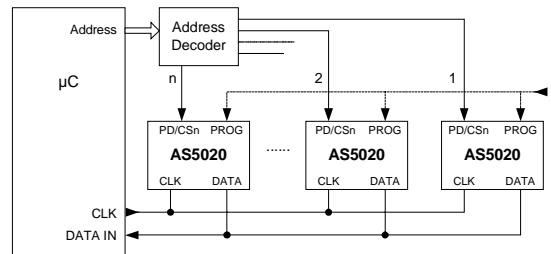

Figure 12 Typical Parallel Configuration

Electrical Characteristics

Absolute Maximum Ratings

Symbol	Parameter	Remarks	Min	Typ	Max	Unit
V _{DD}	Max. Supply Voltage		-0.3		7	V
I _{LUI}	Max. Input Current	Latch-up immunity / Norm JEDEC 17		25		mA
V _{IN}	Max. Digital Input Voltage		-0.3		V _{DD} + 0.3	V
ESD	Electrostatic Discharge	Norm MIL883E method 3015	-1000		+1000	V
T _{Store}	Storage Temperature Range		-50		+125	°C
P _{tot}	Total Power Dissipation				150	mW
H	Humidity non-condensing		5		85	%
	Soldering conditions	Norm: IEC 6170-1	0.7 V _{DD}		V _{DD}	V

Stresses beyond those listed under "Absolute Maximum Ratings" may cause permanent damage to the device. These are stress ratings only. Functional operation of the device at these or any other conditions beyond those indicated under "Operating Conditions" is not implied. Exposure to absolute maximum rating conditions for extended periods may affect device reliability.

Operating Conditions

Symbol	Parameter	Conditions	Min	Typ*	Max	Unit
V _{DD}	Supply Voltage	Measurement mode, V _{SS} =0V	4.75	5.0	5.25	V
T _{AMB}	Ambient Operating Temp. Range		-40		+125	°C
V _{IL}	Input Low Voltage		V _{SS}		0.3 V _{DD}	V
V _{IH}	Input High Voltage**		0.7 V _{DD}		V _{DD}	V

Note: External Buffer Capacitance is needed: e.g. 4.7µF between the supply pins

* typical figures at 25°C are for design aid only; not guaranteed and not subjected to production testing.

** At pin PROG a higher voltage (up to 8.5V) is defined for the zero position programming routine.

DC Characteristics

Symbol	Parameter	Conditions	Min	Typ	Max	Unit
I _{DD}	Operating Supply Current	PD/CSn=0, Continuous Mode	15		24	mA
I _{DDa}	Average Supply Current	1000 samples per second PD/CSn=1 for 33µs/sample	0.98		1.76	mA
I _{DD0}	Power Down Current	PD/CSn=1	0.5		1	mA
I _{OL}	Output Current, Sink	V _{OL} = 0.4V		1		mA

Timing Characteristics

Symbol	Parameter	Conditions	Min	Typ	Max	Unit
t _{setup}	Set up time after power on		20			µs
t _{reset}	Minimum reset duration		1			µs
t _{meas}	Minimum waiting time for a single measurement*		20			µs
t _{CLK_DATA}	Max. CLK-DATA valid delay				10	ns
t _{latch}	Min. hold time after latching		5			µs
t _{CLK}	Min. Clock period			1		µs

* Multiple latching of 1 measured value in Continuous Read Out Mode is possible due to internal anti-collision of Value Update

Programming Input (see Figure 6)

Symbol	Parameter	Conditions	Min	Typ*	Max	Unit
V _{PROG}	Programming Voltage	Measurement mode, V _{SS} =0V	8		8.5	V
I _{PROG}	Programming Current				100	mA
t _{zap}	Zap pulse duration		4.5	5	5.5	µs
t _{Prog}	Programming period		9	10	11	µs
t _{wait}	Minimum waiting time after rising edge of PD/CSn		0.5			µs
t _{ProgEN}	Delay after CSn=1		200			µs
T _{LH}	Pulse slew rate		2			V/µs

Magnetic Input Characteristics

Recommended: cylindrical two pole source diametrically magnetized, Ø3 to 6mm, h=2mm

Symbol	Parameter	Conditions	Min	Typ	Max	Unit
B _{min-max}	Magnetic field strength input range	At chip surface (package surface is 0.5mm above chip) Sinusoidal magnetic field density along concentric circle with 1.6mm diameter.	30	40	50	mT
Off _{mag}	Magnetic Offset	e.g. external, overlapping stray field	-5		5	mT
DistF _{mag}	Magnetic distortion factor (Magnetic field non-linearity)			2	3	%
T _d	Magnet Temperature drift			-0.035		%/K
D	Diameter of encoder magnet		3	6		mm
f	Input frequency	Both directions			30,000	rpm

*Note: Please ask for our preferred Magnet Supplier List.

System Performance

Symbol	Parameter	Conditions	Min	Typ	Max	Unit
RES	Resolution			6		bits
LSB	Least Significant Bit, Minimum step			5.625		deg
INL _{opt}	Optimum Integral Non-Linearity	See Note 2) T=25°, optimum alignment using recommended magnetic source			+/-1.00	deg
INL	Integral Non Linearity	See Note 2) -40 < T < 85°, with specified tolerances See Note 4)			+/-2.813	deg
DNL	Differential Non-Linearity	See Note 2) No missing codes guaranteed			+/-2.813	deg
TN	Transition Noise			+/- 0.25		deg

1. Linearity is defined in terms of end point fit and guaranteed by design, proved by simulated test signals
2. System linearity limited by magnetic source linearity
3. Box method is used to calculate parameter drift over temperature
4. Measured with 6 mm magnet diameter encoder

Magnet Placement *

*Note: These values depend strongly on the magnet

Symbol	Parameter	Conditions	Min	Typ	Max	Unit
R _{Disp}	Displacement radius of rotational axis with reference to pins	Magnet centered on rotational axis	-0.25		+0.25	mm
Z _{Dist}	Distance between permanent magnet and package surface	With reference magnet (depends on magnet used)		1		mm

Output Data Format

Data	Description	Condition	Output
D<5:0>	6 bit Angular Data	Position 0 Position 63	000000 _{bin} 111111 _{bin}
NVR	Non Valid Range Bit	Magnetic Field out of NVR	1
PARITY	Parity bit		even parity

Mechanical Dimensions

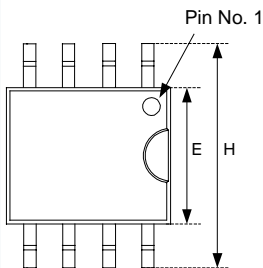
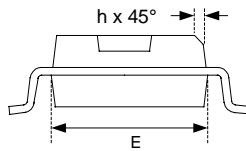
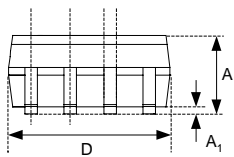

	Common Dimensions (in mm)		
	min.	nom.	max.
A	1,55	1,63	1,73
A ₁	0,127	0,15	0,25
D	4,80	4,93	4,98
E	3,81	3,94	3,99
H	5,84	5,99	6,20

Available Documents

Magnet Supplier List

Application Notes:

- Absolute Angular and Linear Measurement using the AS5020
- Contactless Position and Speed Measurement of the Rotor in Electric Motors
- Magnetic Properties required for use with the AS5020

Preliminary data sheet AS5021 – Incremental Rotary Encoder

Ordering Information

AS5020 6-bit absolute angular encoder

Package: SOIC-8 Narrow Body

Delivery: Tape and Reel (1 reel = 2500 devices)
Tubes (1 box = 100 tubes á 97 devices)

Order # 4672-001 for delivery in tubes

Order # 4672-201 for delivery in tape and reel

Contact

Headquarters

austriamicrosystems AG
 A 8141 Schloss Premstätten, Austria
 Tel: +43 (0) 3136 500 0
 Fax: +43 (0) 3136 525 01
 e-mail: amadeus@austriamicrosystems.com
 www.austriamicrosystems.com

Sales Offices

austriamicrosystems Germany GmbH
 Tegernseer Landstrasse 85
 D-81539 München, **Germany**
 phone: +49 (0) 89 69 36 43 0
 fax : +49 (0) 89 69 36 43 66

austriamicrosystems France S.A.R.L.
 124, Avenue de Paris
 F-94300 Vincennes, **France**
 phone: +33 1 43 74 00 90
 fax : +33 1 43 74 20 98

austriamicrosystems UK, Ltd.
 Coliseum Business Centre
 Watchmoor Park
 Camberley, Surrey
 England GU15 3YL, **United Kingdom**
 phone: +44 1276 23 3 99
 fax : +44 1276 29 3 53

austriamicrosystems Switzerland AG
 Rietstrasse 4
 CH-8640 Rapperswil, **Switzerland**
 phone: +41 (0) 55 220 9008
 fax : +41 (0) 55 220 9001

austriamicrosystems USA, Inc.
 8601 Six Forks Road
 Suite 400
 Raleigh, NC 27615
USA
 phone: +1 919 676 5292
 fax : +1 509 696 2713

austriamicrosystems Japan, AG
 Shin Yokohama Daini Center Bldg. 10F
 3-19-5, Shin Yokohama
 Kohoku-ku, Yokohama 222-0033
Japan
 phone: +81 45 474 0962
 fax : +81 45 472 9845

Copyright

Devices sold by austriamicrosystems are covered by the warranty and patent indemnification provisions appearing in its Term of Sale. austriamicrosystems makes no warranty, express, statutory, implied, or by description regarding the information set forth herein or regarding the freedom of the described devices from patent infringement. austriamicrosystems reserves the right to change specifications and prices at any time and without notice. Therefore, prior to designing this product into a system, it is necessary to check with austriamicrosystems for current information. This product is intended for use in normal commercial applications.

Copyright © 2001 austriamicrosystems. Trademarks registered ®. All rights reserved. The material herein may not be reproduced, adapted, merged, translated, stored, or used without the prior written consent of the copyright owner. To the best of its knowledge, austriamicrosystems asserts that the information contained in this publication is accurate and correct. However, austriamicrosystems shall not be liable to recipient or any third party for any damages, including but not limited to personal injury, property damage, loss of profits, loss of use, interruption of business or indirect, special, incidental or consequential damages, of any kind, in connection with or arising out of the furnishing, performance or use of the technical data herein. No obligation or liability to recipient or any third party shall arise or flow out of austriamicrosystems rendering of technical or other services